

## NON-SLAM CHECK VALVE

Avarus Valves membrane check valve is designed to provide the best possible protection to pump installations and water networks by guaranteeing a quiet, smooth, non-slam operation. The check valve has a rubber membrane seal which helps to absorb cavitation and damaging surge sometimes associated with water networks and pump stoppage.



### Features

- Sizes 50mm to 500mm.
- Non-slam, quiet operation.
- Decreases water hammer.
- Ductile iron, epoxy coated with EPDM membrane seal.
- Horizontal or vertical installation.

### Application

- Suitable for water, working pressure up to 16 bar. Operating temperature -10 to +80°C.

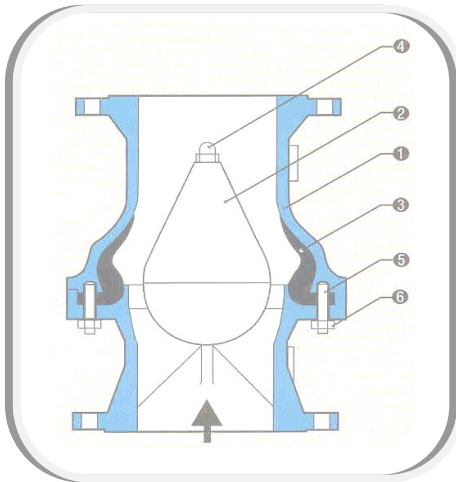

### Parts

1. Body — Ductile iron.
2. Cone — Ductile iron.
3. Membrane — EPDM rubber.
4. Safety nut — Bronze.
5. Studs — Galvanised steel.
6. Nuts — Galvanised steel.

Parts 1 & 2 coated with Resicoat R4 - WRAS Approved

Valve size mm	50	65	80	100	125	150	200	250	300	350	400	500
Face to Face	240	240	260	315	350	400	500	600	700	800	900	1100
Width	180	180	220	220	292	292	374	450	550	650	720	985
Weight (kg)	12	14.5	22	23	41	44	83	132	205	291	412	766

Please consult **Avarus Valves Limited** if we can be of any assistance.